

LOCTITE

1001 Trout Brook Crossing
Rocky Hill, CT 06067-3910
Telephone: (860) 571-5100
FAX: (860) 571-5465

Product Description Sheet

Hysol® 050-LITE Hot Melt Applicator

Part # 98029

North American Equipment, August 2001

PRODUCT DESCRIPTION

Loctite® Hysol® 050-LITE Lightweight Hot Melt Applicator is a hand-held dispenser which utilizes a finger-actuated trigger mechanism to positively grip and advance all Loctite Hysol 1/2" structural hot melt sticks.

PRODUCT FEATURES

- Fixed precision temperature setting: 392°F (200°C)
- Interchangeable nozzles
- Class 1 insulation
- Wire stand for stability

Bench Space Requirements

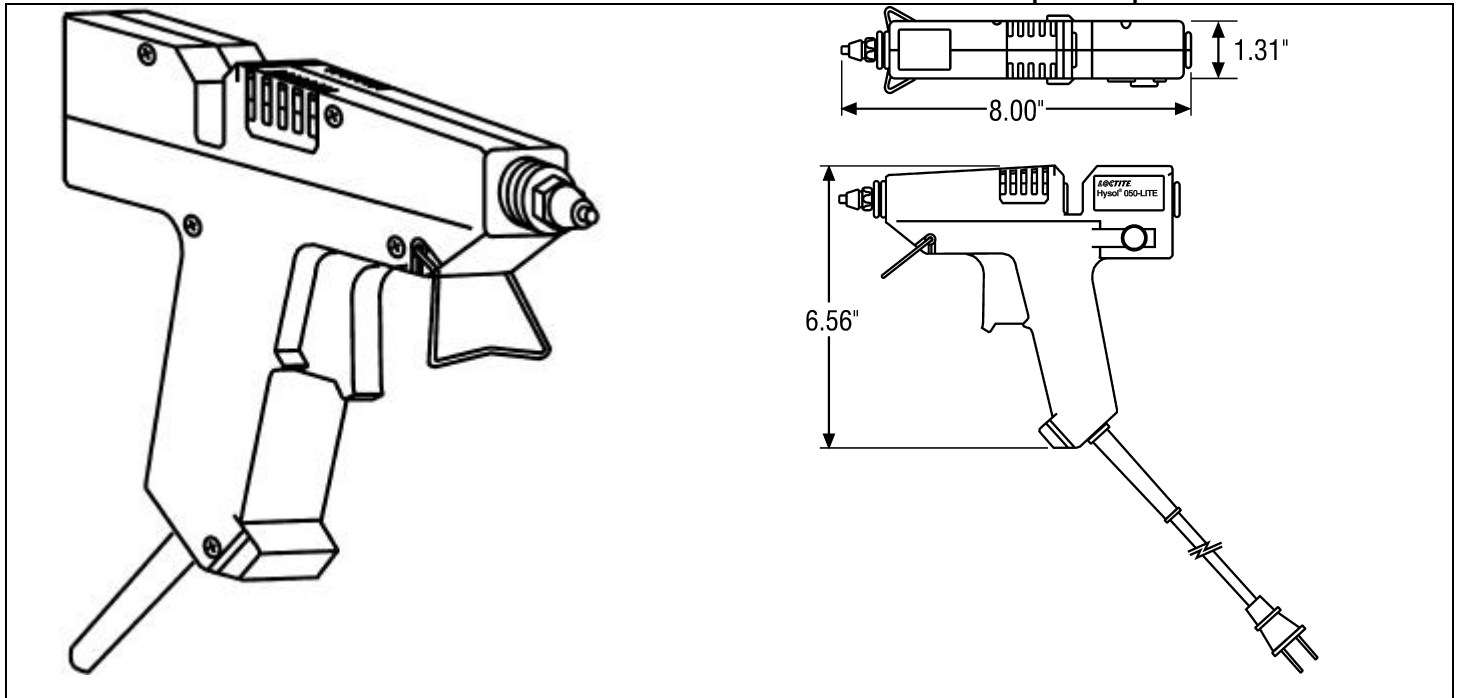

Technical Data

- Melt rate output: Up to 1.0 lb./hr (0.45 Kilo)
- Adhesive: 1/2 inch diameter Supersticks
- Voltage: 100/240 VAC, (Electronically self adjusting) 50/60 Hz, single phase
- Power: 20 to 500 Watts (Electronically self regulating)
- Weight: 0.75 pounds (390 grams)

Hot Melt Stick Dispenser P/N 98029 Includes:

- Instruction manual - P/N 984913
- Hysol 050-LITE Hot Melt Stick Applicator
- Applicator wire stand - P/N 984914

Optional accessories:

- Replacement standard nozzle, .10" DIA x .16"LG - P/N 984999
- Spreader nozzle, (.06"x.25'SQ) x .47"LG - P/N 985001
- Pencil point nozzle, .08"DIA x .24"LG - P/N 985002
- Precision nozzle, .05"DIA x .20"LG - P/N 985003
- Extension nozzle, .10"DIA x .50"LG - P/N 985004
- Rubber nozzle shroud - P/N 985005
- Tool hanger/balancer - P/N 985243

NOT FOR PRODUCT SPECIFICATIONS
PLEASE CONTACT LOCTITE CORPORATION FOR ASSISTANCE: 1-800-LOCTITE (1-800-562-8483)

The data contained herein are furnished for information only and are believed to be reliable. We cannot assume responsibility for the results obtained by others over whose methods we have no control. It is the user's responsibility to determine suitability for the user's purpose of any production methods mentioned herein and to adopt such precautions as may be advisable for the protection of property and of persons against any hazards that may be involved in the handling and use thereof. In light of the foregoing, LOCTITE CORPORATION SPECIFICALLY DISCLAIMS ALL WARRANTIES EXPRESSED OR IMPLIED, INCLUDING WARRANTIES OF MERCHANTABILITY OR FITNESS FOR A PARTICULAR PURPOSE, ARISING FROM SALE OR USE OF LOCTITE CORPORATION'S PRODUCTS. LOCTITE CORPORATION SPECIFICALLY DISCLAIMS ANY LIABILITY FOR CONSEQUENTIAL OR INCIDENTAL DAMAGES OF ANY KIND, INCLUDING LOST PROFITS. The discussion herein of various processes or compositions is not to be interpreted as representation that they are free from domination of patents owned by others or as a license under any Loctite Corporation patents that may cover such processes or compositions. We recommend that each prospective user test his proposed application before repetitive use, using this data as a guide. This product may be covered by one or more United States or foreign patents or patent applications.

Loctite and Hysol are trademarks of Loctite Corp. U.S.A.