



EQUIPMENT Operation Manual



Loctite® Hysol® 075

120 Volt Part No. 98033, 230 Volt Part No. 98053

Loctite® Hysol® 075-LT

120 Volt Part No. 98034, 230 Volt Part No. 98054

Table of Contents

1	Please observe the following.....	3
1.1	Emphasized Sections.....	3
1.2	For Your Safety.....	3
1.3	Items Supplied.....	3
2	Description.....	4
3	Technical Data.....	4
4	Installation.....	5
4.1	Exploded View.....	6
4.2	Parts List.....	7
5	Operation.....	8
5.1	Start up.....	8
5.2	Shut down.....	9
5.3	Temperature Adjustment	9
5.4	Application Hints.....	9
6	Care and Maintenance.....	10
7	Troubleshooting.....	11
8	Documentation.....	12
8.1	Spare Parts	12
8.2	Accessories.....	13
9	Warranty.....	14

1 Please Observe the Following

1.1. Emphasized Sections



Warning!

Refers to safety regulations and required safety measures that protect the operator or other persons from injury.



Notice:

Gives recommendations for better handling of the machine during operation or adjustment as well as for service activities.



Caution!

Emphasizes what must be done or avoided so that the unit or other property is not damaged.

1.2 For Your Safety

- For safe and successful operation of this machine, read these instructions completely. If the instructions are not observed, the manufacturer can assume no responsibility.
- Observe general safety regulations for the handling of chemicals such as Loctite® adhesives and sealants. Observe the manufacturer's instructions as stated in the **Material Safety Data Sheet (MSDS)**.
- While under warranty, the machine may be repaired only by an authorized Henkel Loctite service representative.
- Wear heat resistant leather gloves when operating or maintaining a hot tool.
- Always use care when dispensing hot melt adhesive.
- Nozzle temperature and adhesive may reach 400°F. Avoid skin contact with nozzle or adhesive.
- If molten adhesive is accidentally deposited on skin, immerse immediately in cold water. **DO NOT ATTEMPT TO REMOVE LARGE AMOUNTS OF GLUE FROM SKIN WITHOUT FIRST SECURING PROPER MEDICAL ATTENTION.**
- Check that the surface to be bonded will not melt or be damaged by the temperature of the adhesive.
- Do not use the tool in damp or wet areas.
- Always use a properly grounded 120V/230V outlet. Do not remove the grounding prong from the machine electrical plug.
- A qualified electrician or appliance repair person should perform machine repair.

1.3 Items Supplies

- Hysol® 075 or Hysol® 075-LT Hot Melt Dispenser
- Instruction manual
- Stand-Off Wings
- Dispenser Stand
- Speed Loader

2 Description

Loctite® Hysol® 075 and the Hysol® 075-LT are specifically designed to dispense the full range of Hysol® 3/4" diameter Maxistick hot melt adhesives. The Loctite® Hysol® 075 hot melt applicator contains two powerful 200W stainless steel cartridge heaters, while the Hysol® 075- LT version contains a single 200W stainless steel cartridge heater. Both dispensers feature a totally enclosed heater housing, a sealed thermostatic switch, and thermal fuse protection, providing accuracy in temperature control and excellent reliability. These applicators only take 5 minutes to warm up, yet the Hysol® 075 is capable of dispensing up to 9 lbs. of molten hot melt per hour and the Hysol® 075-LT can dispense up to 5 pounds/hour. Loctite® Hysol® 075 and the Hysol® 075-LT are the highest output, hand-held dispensers in their class.

3 Technical Data

Dimensions (L x H x W)	approx. 11- 3/4"x 9-1/4" x 1-7/8"
Total weight:	18 oz (500g)
Operating voltage:	
Hysol® 075:	120V, 3.3 amp, Single Phase 230V, 1.7 amp, Single Phase
Hysol® 075-LT:	120V, 1.7 amp, Single Phase 230V, 0.9 amp, Single Phase
Power consumption:	
Hysol® 075:	400W
Hysol® 075-LT:	200W
Warm up time:	Approximately 5 minutes
Operating temperature:	
Hysol® 075:	360°F (182°C)
Hysol® 075-LT:	250°F (121°C)
Diameter of adhesive inlet:	3/4"
Extension cable:	max. 65ft (20 m) long
Wire cross section:	at least 16 a.w.g. (1.5 mm ²)

4 Installation

Notice:

Before using the dispenser for the first time: Check it carefully for signs of external damage. If any shipping damage is found DO NOT USE THE TOOL - return it to your supplier immediately.

- Attach the enclosed stand to the dispenser by locating the slot at the base of the handle grip.
- Snap the standoff wings into upper vent slots on left and right side of dispenser. These enable the dispenser to be laid on its side without blocking the side vents.
- To install the speed loader, orient it as shown in the illustration (on next page) and push it down over the magazine cavity. Align the four holes in the Speed Loader with the four tabs on the outside of the magazine chamber and pinch the sides of the Speed Loader to snap the holes over the tabs.
- To load a hot melt stick into the Speed Loader, hold the dispenser with the nozzle pointed down slightly from the horizontal position. Insert the stick and push it forward until it drops into place. Insert a second stick on top of the first.
- To drop one of the reserve sticks into the magazine chamber, hold the dispenser horizontally and pull back quickly on the plunger knob. The stick should drop in fully.

4.1 Exploded View

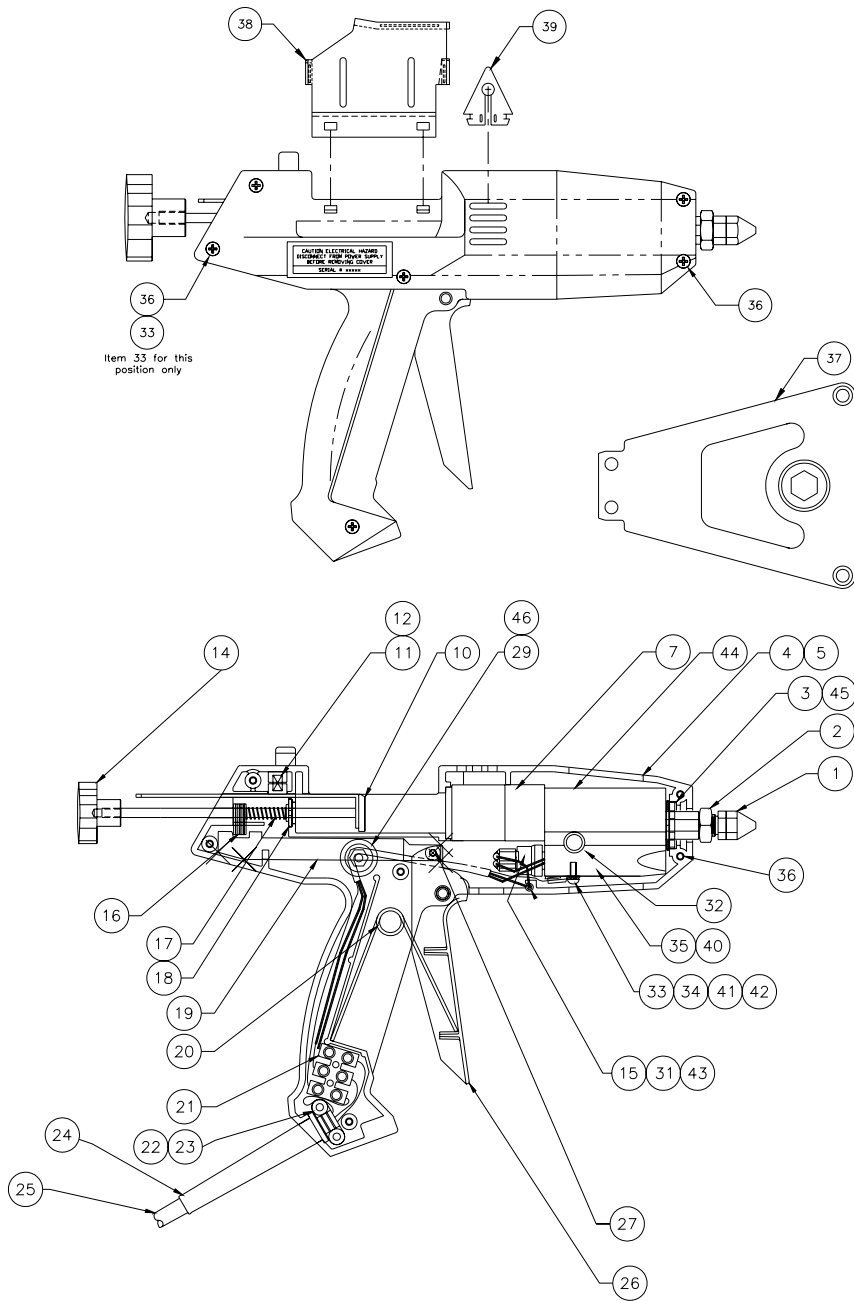

4.2 Parts List

ITEM	QTY.	DESCRIPTION	INCLUDED IN PART NUMBER	AVAILABLE PART NO.
46	1	STARLOK WASHER	985309	
45	1	WASHER / SPACER	987907	
44	1	HEATER HOUSING ASSEMBLY	987907	
43	1	FEMALE DISCONNECT TERMINAL	988776	
42	1	RING TERMINAL	987907	
41	1	GROUND WIRE, 10 INCHES LONG	987907	
40	1	HEATER, 120 VOLT, 200 WATT, HYSOL 075-LT	985307	
	1	HEATER, 230 VOLT, 200 WATT, HYSOL 075-LT	985753	
39	2	STAND-OFF WINGS	985309	
38	1	SPEED LOADER, PACKAGE OF 10		IZZ020N10
37	1	DISPENSER STAND, PACKAGE OF 10		IZZ002N10
36	6	SELF TAPPING SCREW	985309	985102
35	2	HEATER, 120 VOLT, 200 WATT, HYSOL 075	985306	
	2	HEATER, 230 VOLT, 200 WATT, HYSOL 075	985749	
34	1	SLOTTED ROUND HEAD SCREW	987907	
33	2	HELICAL SPRING LOCK WASHER #6	987907	
32	1	THERMAL FUSE ASSEMBLY	988776	
31	1	THERMOSTAT, 360° F, HYSOL 075, 5 PACK		EST005N05
29	1	WASHER, INSULATOR	985309	
27	1	LINK PIN	985310	
26	1	TRIGGER	985310	
25	1	CORDSET 3 PRONG UL	985312	
	1	AUSTRALIAN CORDSET	985752	
24	1	CORD GUARD	985312	
23	2	SELF TAPPING SCREW	985312	
22	1	CORD RETAINER	985312	
21	1	TERMINAL STRIP, 3 POLE	985312	
20	1	TORSION SPRING 65 DEGREES	985310	
19	1	FEED LINK	985310	
18	1	BUSHING	985308	
17	1	COMPRESSION SPRING, .20 X 1.0 X .018	985308	
16	6	GRIPPING PLATES	985308	
15	1	THERMOSTAT, 250°, HYSOL 075-LT, 5 PACK		EST009N05
14	1	PUSH / PULL KNOB	985308	
12	1	COMPRESSION SPRING, 3/16 X 3/4 X .018	985313	
11	2	SLIDE SNUBBER	985313	
10	1	ROD / SLIDE PLUNGER ASSEMBLY	985308	
7	2	O-RING, 21.6MM - 2.4MM VT70	987907	
		O-RING, 21.6MM - 2.4MM VT70, PKG OF 10		985858
5	1	RIGHT HANDLE	985309	
4	1	LEFT HANDLE	985309	
3	1	MELT CHAMBER COLLAR	987907	
2	1	NOZZLE ADAPTER ASSEMBLY		ANZ023N01
1	1	NOZZLE .081 ORIFICE	985225	

SEE SECTION 8.1 FOR AVAILABLE SPARE PARTS KITS

5. Operation

5.1 Start Up

! **Caution:** The dispenser should have a suitable resting place to facilitate easy operator access and good ventilation around the tool. Good ventilation is necessary to prevent melt down.

! **Caution:** For good ventilation, the dispenser should always be positioned when idle so that air is free to circulate around the dispenser. This is particularly important when the ambient temperature is summer-like.

! **Caution:** When idle, the nose of the dispenser should not be angled down too sharply or heat from the front of the dispenser will flow over the back of the dispenser.

! **Caution:** Always use a dispenser stand. The purpose of the dispenser stand is to hold the dispenser when it is not in use in a position that will facilitate ventilation and cooling of the dispenser.

- Pull back on the knob at the rear of the dispenser to retract the glue stick plunger.
- Insert one Maxistick hot melt stick into the magazine cavity of the tool. Use only Hysol® Maxistick hot melt sticks. The use of other adhesive brands will void any tool warranty.
- Plug the power cord into a properly grounded 120V/230V, 15 amp outlet. There is no power switch. Allow 5 minutes for the melt chamber to warm to operating temperature.

 Do not touch the discharge nozzle as it can cause a serious skin burn.

- Point the nozzle of the dispenser in a safe direction and actuate the trigger to advance the glue stick to fill the melt chamber. This first stick will only fill the melt chamber. Little or no adhesive will discharge.
- Stop actuating the trigger when the plunger is fully advanced. This will be indicated when the knob contacts the back of the tool housing.
- Insert a second hot melt stick and actuate the trigger again. Hot melt should begin to discharge from the nozzle.
- If the trigger is hard to actuate, allow five minutes for the dispenser to warm to full operating temperature.
- If the trigger will not operate, check the plunger. If fully advanced, retract it and reload another hot melt stick.

5.2 Shut Down

 **Notice:** To prevent hot melt waste, pull the power plug just before the last bonding operation. There is enough residual heat in the melt chamber to dispense one full hot melt stick without power.

- Easy start-up of a hot melt applicator can be affected by the method of shut down.
- Step one: pull the plug from the power outlet.
- Step two: actuate the trigger to dispense at least one half of a hot melt stick.
- Allow the dispenser to cool down in a proper idle position to facilitate good ventilation.

5.3 Temperature Adjustment

The operating temperature of the Hysol® 075 and Hysol® 075-LT are fixed by a sealed thermostatic switch. The thermostatic set points are factory set and are not user adjustable. The standard operating temperature for the Hysol® 075 is 360° F (182° C) and the Hysol® 075-LT is 250° F (121° C).

5.4 Application Hints

- As with all adhesives, performance depends on conditions of use. Suggestions or recommendations contained herein are for guidance only, since actual conditions of use are outside the supplier's control.
- Ensure that the surfaces to be bonded are dry, free from dust, grease, and loose particles.
- Apply adhesive to one surface only. Bring the two surfaces together immediately, quickly making any further adjustments. Hold the joint for 20 - 30 seconds to complete the bond.
- When bonding dissimilar materials, apply the adhesive to the least heat conductive of the two.
- On materials that are cold to the touch, a better bond can be made by warming them before applying adhesive.
- Surplus adhesive can be trimmed using a sharp knife once it has cooled. Should molten adhesive drip onto a smooth or polished surface, allow it to cool completely before removal.
- Spots or blobs of adhesive are recommended for work pieces having a large surface area, or which are particularly long.
- Applying the adhesive in wavy lines is recommended for gluing textiles or similar materials.
- Foam materials, like polystyrene, can be easily bonded to other surfaces. However the adhesive must be applied to the other surfaces, not to the foam.
- Use only genuine Hysol® adhesive sticks to ensure reliable performance. Hysol® adhesive sticks are non-toxic and non-flammable.

6 Care and Maintenance

Every attempt has been made to make this exceptionally powerful dispenser both reliable and trouble-free. However the following precautions should be noted:

- When in use, do not lay the dispenser on its side - always place upright using the stand provided.
- Do not use excessive force on the trigger. Ensure that the dispenser has fully warmed up before use.
- Keep the nozzle clean to prevent adhesive build-up. This is easily done by wiping the nozzle with clean paper or cloth while the nozzle is still warm.
- Should “melt down” accidentally occur, switch off the dispenser and allow the adhesive to cool. Gently pull away this excess adhesive, reconnect the power, and allow the dispenser to warm up again. Squeeze the trigger two or three times to advance the hot melt stick, then use the dispenser as normal.



Replace the nozzle if worn or damaged. **Only replace the nozzle while the tool is still warm. Disconnect the dispenser from the power supply before proceeding, and always use protective gloves.** Unscrew the nozzle from the dispenser using either a 1/2” (13 mm) spanner, or the spanner-feature molded into the gun stand. Assemble the replacement nozzle, ensuring that it is securely tightened.

Glue “Melt back” and “Melt down”

“Melt down” occurs when hot molten adhesive in the glue chamber is forced back between the feed chamber sleeve and the outside surface of the adhesive stick. Once this adhesive cools, it may lock the adhesive stick in the feed chamber sleeve, preventing, or at least restricting, normal extrusion. By far the most likely cause of melt back is not allowing sufficient warm-up time before operating the dispenser (the molten glue in the glue chamber cannot escape forwards because the nozzle is blocked due to being insufficiently warm). In the vast majority of cases the melt back self-clears once the dispenser, having fully reached operating temperature, is operated again.

“Melt back” occurs when the rear of the adhesive stick softens to the extent that it is not rigid enough to drive the stick forward without collapsing. As with melt down, the molten adhesive can solidify, potentially locking the stick in the feed chamber sleeve. Melt down is caused by leaving the tool switched on for extended periods of time without operating it. **It is recommended that, if the dispenser is to be left standing for forty minutes or more, it should be switched off and only switched back on when preparing to use it again.**



The Loctite® Hysol® 075 and 075-HT dispensers are fitted with a Teflon feed chamber sleeve which has non-stick characteristics; this minimizes the effect of any melt back or melt down, should it occur.

7 Troubleshooting

Notice:

Electrical troubleshooting must be performed by a qualified electrician or appliance repair person.

Problem	Possible Cause	Correction
No Heat	- No power to dispenser	• Check main power supply
	- Faulty thermostat	• Check for electrical continuity when cold. Replace if switch is open.
	- Blown Thermal Cut Out (TCO)	• Check continuity and replace if open.
	- Discontinuity of circuit	• Check butt splice in TCO circuit and screw terminals for good connection.
	- Faulty heater	• Isolate and check for discontinuity and replace
Inadequate Heat	- Dispenser is not fully heated	• Allow 5 minutes to reach operating temperature.
	- Defective thermostat	• Change thermostat
	- One (of two) faulty heating element	• Isolate and check for discontinuity
Trigger is hard to actuate	- Dispenser is not fully heated	• Allow 5 minutes to reach operating temperature.
	- Plunger is bottomed out	• Retract plunger and load another adhesive stick.
	- Adhesive stick diameter is too large	• Consult adhesive distributor
High trigger force is required to advance glue stick upon start up. Stick then advances easily.	- Improper shut down from previous use.	• Pull power plug just before last application. Dispense at least half of a glue stick without power to tool.
Adhesive leaks back from melt chamber into feed magazine area	- Dispenser is not ventilated properly	• Refer to Installation information
	- Adhesive stick diameter is too small	• Consult adhesive distributor
	- Thermostat loose	• Isolate and check for tightness
Trigger moves but does not advance the plunger reliably.	- Feed mechanism is worn	• Replace the plunger assembly

8 Documentation

8.1 Spare Parts

	Part #
1. Nozzle Adapter Assembly, item 2	ANZ023N01
2. Speed Loader, item 38, pkg of 10	IZZ020N10
3. Dispenser Stand, item 37, pkg of 10	ISZ002N10
4. Heater Assembly Kit, Hysol® 075-120V	985306
Heater Assembly Kit, Hysol® 075-230V	985749
Qty 2 – Heaters, item 35	
Qty 1 – Female Terminal, item 43	
5. Heater Assembly Kit, Hysol® 075-LT-120V	985307
Heater Assembly Kit, Hysol® 075-LT-230V	985753
Qty 1 – Heaters, item 35	
Qty 1 – Female Terminal, item 43	
6. Thermal Fuse (TCO) Assembly	988776
Qty 1 - Thermal Fuse (TCO), item 32	
7. Thermostat	
Hysol® 075, item 31, pkg of 5	EST005N05
Hysol® 075-LT, item 15, pkg of 5	EST009N05
8. Plunger Assembly Kit	985308
Qty 1 – Knob, item 14	
Qty 6 – Gripping Plates, item 16	
Qty 1 – Spring, item 17	
Qty 1 – Bushing, item 18	
Qty 1 – Plunger Rod Slide, item 10	
9. Handle Kit	985309
Qty 1 – Right Handle, item 5	
Qty 1 – Left Handle, item 4	
Qty 6 – Screws, item 36	
Qty 1 – Starlok washer, item 46	
Qty 1 – Washers Insulator, item 29	
Qty 2 – Standoff wings, item 39	
10. Trigger Kit	985310
Qty 1 – Trigger, item 26	
Qty 1 – Feed Link Grip Plate, item 19	
Qty 1 – Pin Link, item 27	
Qty 1 – Torsion Spring, item 20	
11. Melt / Feed Chamber Sleeve Kit	987907
Qty 1 – Heater Housing Assembly, item 44	
Qty 2 – O-Ring #202-647, item 7	
Qty 1 – Helical Spring Lock Washer, item 33	
Qty 1 – Ground screw, item 34	
Qty 1 – Melt Chamber Collar, item 3	
Qty 1 – Ground Wire, item 41	
Qty 1 – Ring Terminal, item 42	
Qty 1 – Spacer, item 45	

8.1 Spare Parts (Continued)

12. U.S. Cordset Kit, 120 volt	985312
Australian Cordset Kit, 230 volt	985752
Qty 1- Terminal Block, item 21	
Qty 1 – Cord Retainer, item 22	
Qty 2 – Screws, item 23	
Qty 1 – Cord Guard, item 24	
Qty 1 – Cordset, 3 prong, item 25	
13. Snubber Kit	985313
Qty 2 – Snubber Slide, item 11	
Qty 1 – Spring, item 12	
14. O-Ring, 21.6mm-2.4mm, item 7, pkg of 10	985858
15. Label Kit for 98033	985853
16. Label Kit for 98034	985854
17. Label Kit for 98053	985855
18. Label Kit for 98054	985856

8.2 Accessories

Accessories	Part Number
Replacement Nozzle Adapter Assembly	ANZ023N01
Standard Nozzle 1-Hole Kit, Qty 5, 0.080” (2 mm) orifice	985225
Nozzle 2-Hole	985110
Nozzle 3-Hole	985111
Extension Nozzle 0.120” (3 mm)	985112
Needle Extension Nozzle 0.050” (1.3 mm)	985113
Spreader Extension Nozzle 0.250” (6 mm)	985114
“L” Nozzle, overlap carton sealing	985115
“T” Nozzle, center flap carton sealing	985116
Tool Hanger / Balancer	985243

9 Warranty

Henkel Loctite expressly warrants that all products referred to in this Instruction Manual for Hysol® 075 and Hysol® 075-LT hot melt dispensers, (hereafter called “Products”), shall be free from defects in materials and workmanship. Liability for Loctite shall be limited, as its option, to replacing those Products which are shown to be defective in either materials or workmanship or to credit the purchaser the amount of the purchase price thereof (plus freight and insurance charges paid therefor by the user). The purchaser’s sole and exclusive remedy for breach of warranty shall be such replacement or credit.

A claim of defect in materials or workmanship in any Products shall be allowed only when it is submitted in writing within one month after discovery of the defect or after the time the defect should reasonably have been discovered and in any event, within 1 year after the delivery of the Products to the purchaser. This warranty does not apply to perishable items, such as fuses. No such claim shall be allowed in respect of products which have been neglected or improperly stored, transported, handled, installed, connected, operated, used or maintained. In the event of unauthorized modification of the Products including, where products, parts or attachments for use in connection with the Products are available from Henkel Loctite, the use of products, parts or attachments which are not manufactured by Henkel Loctite, no claim shall be allowed.

No Products shall be returned to Henkel Loctite for any reason without prior written approval from Henkel Loctite. Products shall be returned freight prepaid, in accordance with instructions from Henkel Loctite.

NO WARRANTY IS EXTENDED TO ANY EQUIPMENT WHICH HAS BEEN ALTERED, MISUSED, NEGLECTED, OR DAMAGED BY ACCIDENT, OR IF THE SYSTEM IS USED TO DISPENSE ANY LIQUID MATERIAL OTHER THAN HENKEL LOCTITE PRODUCTS.

EXCEPT FOR THE EXPRESS WARRANTY CONTAINED IN THIS SECTION, HENKEL LOCTITE MAKES NO WARRANTY OF ANY KIND WHATSOEVER, EXPRESS OR IMPLIED, WITH RESPECT TO THE PRODUCTS.

ALL WARRANTIES OF MERCHANTABILITY, FITNESS FOR A PARTICULAR PURPOSE, AND OTHER WARRANTIES OF WHATEVER KIND (INCLUDING AGAINST PATENT OR TRADEMARK INFRINGEMENT) ARE HEREBY DISCLAIMED BY HENKEL LOCTITE AND WAIVED BY THE PURCHASER.

THIS SECTION SETS FORTH EXCLUSIVELY ALL OF THE LIABILITY FOR HENKEL LOCTITE TO THE PURCHASER IN CONTRACT, IN TORT OR OTHERWISE IN THE EVENT OF DEFECTIVE PRODUCTS.

WITHOUT LIMITATION OF THE FOREGOING, TO THE FULLEST EXTENT POSSIBLE UNDER APPLICABLE LAWS, HENKEL LOCTITE EXPRESSLY DISCLAIMS ANY LIABILITY WHATSOEVER FOR ANY DAMAGES INCURRED DIRECTLY OR INDIRECTLY IN CONNECTION WITH THE SALE OR USE OF, OR OTHERWISE IN CONNECTION WITH, THE PRODUCTS, INCLUDING, WITHOUT LIMITATION, LOSS OF PROFITS AND SPECIAL, INDIRECT OR CONSEQUENTIAL DAMAGES, WHETHER CAUSED BY NEGLIGENCE FROM HENKEL LOCTITE OR OTHERWISE.

Henkel Corporation
1001 Trout Brook Crossing
Rocky Hill, CT 06067-3910

Henkel Canada Corporation
2225 Meadowpine Boulevard
Mississauga, Ontario L5N 7P2

Henkel Capital, S.A. de C.V.
Calzada de la Viga s/n Fracc. Los Laureles
Loc. Tulpetlac, C.P. 55090
Ecatepec de Morelos, Edo. de México

**Henkel Automotive
Technology Center**
2455 Featherstone Road
Auburn Hills, Michigan 48326

Henkel Ltda.
Rua Karl Huller, 136 – Jd.
Canhema 09941-410
Diadema/SP, Brazil

www.loctite.com

Loctite is a trademark of Henkel Corporation, U.S.A. © Copyright 2004. Henkel Corporation
All rights reserved. Data in this operation manual is subject to change without notice.
Manual P/N: 985315, Rev F, 06/04

 **Henkel Technologies**