

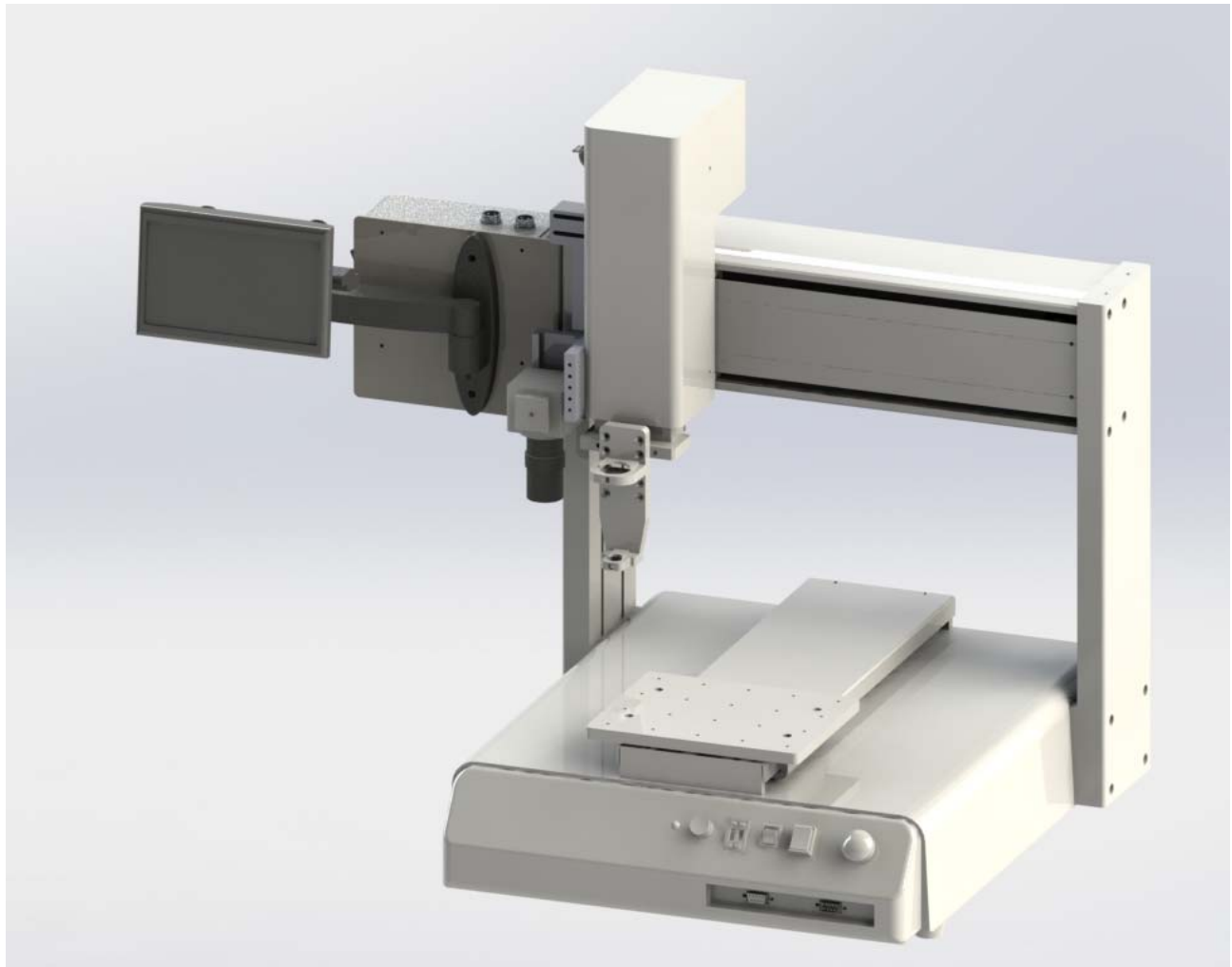

Equipment
Operation Manual



Loctite® RB30 Robot Camera

Part Number: 1912406

Table of Contents

1#	<i>Please Observe the Following</i>	3#
1.1#	<i>Emphasized Sections</i>	3#
1.2#	<i>For Your Safety</i>	3#
1.3#	<i>Safety Precaution</i>	4#
1.4#	<i>Unpacking</i>	4#
1.5#	<i>Overview</i>	4#
2#	<i>Install Camera</i>	6#
2.1#	<i>Hardware Installation</i>	6#
2.2#	<i>Wire Connection</i>	8#
3#	<i>Get Started</i>	9#
3.1#	<i>CCD Setup</i>	9#
3.2#	<i>Tip Setup</i>	10#
3.3#	<i>Edit Path Mode</i>	11#
4#	<i>Accessories & Spare Parts</i>	11#
5#	<i>Equipment Warranty</i>	12#

1 Please Observe the Following

1.1 Emphasized Sections

 **WARNING!**

Refers to safety regulations and required measures that protect the operator or other persons from injury or danger to life.

 **Caution!**

Emphasizes what must be done or avoided so that the unit or other property is not damaged.

 **Notice:**

Gives recommendations for better handling of the unit during operation or adjustment, as well as for service activities.

1.2 For Your Safety

For safe and successful operation of the unit, read these instructions completely. If the instructions are not observed, the manufacturer can assume no responsibility. Be sure to retain this manual for future reference.

 **WARNING!**

Always wear temperature resistance gloves before touch the housing of dispensing head or pre heater.

 **WARNING!**

Never remove the cover of the unit without first switching the power off and unplugging the power cord.

 **WARNING!**

Damage to the power cord or the housing can result in contact with live electrical parts. Check the power cord and housing before each use. If the power cord or unit is damaged, do not operate.

The unit may be repaired only by a Loctite® authorized service technician.

1.3 Safety Precaution

In order to meet the requirements of the European Community (CE) safety directives, the robot must be placed in an enclosure supplied by Henkel.

- Make sure the robot is connected to a properly grounded power source before operating.
- Keep away from any moving parts while the robot is running.
- Loading and unloading of parts and material must only be done when the robot is at a complete stop.
- Changing of fixtures or tooling must be done with the power source disconnected.
- The EQ RB30 Robot Camera should only be operated in an environment between 10 and 40 degrees Celsius with humidity of 20 to 95 percent and no visible condensation.
- Do not store or setup the robot in an area where it is directly exposed to sunlight.
- Do not operate the robot where electrical noise is present.
- Only use a neutral chemical for cleaning the robot. Do not use alcohol, benzene or thinner as it may damage the paint on the robot.

1.4 Unpacking

- Lift with care
- Remove all accessories from the shipping package before attempting to remove the camera.
- Place the camera on a stable workbench before operating.

If you can, do not discard the packing material as these items may be needed if the robot camera is shipped or moved in the future.

1.5 Overview

Note: Robot is not included.

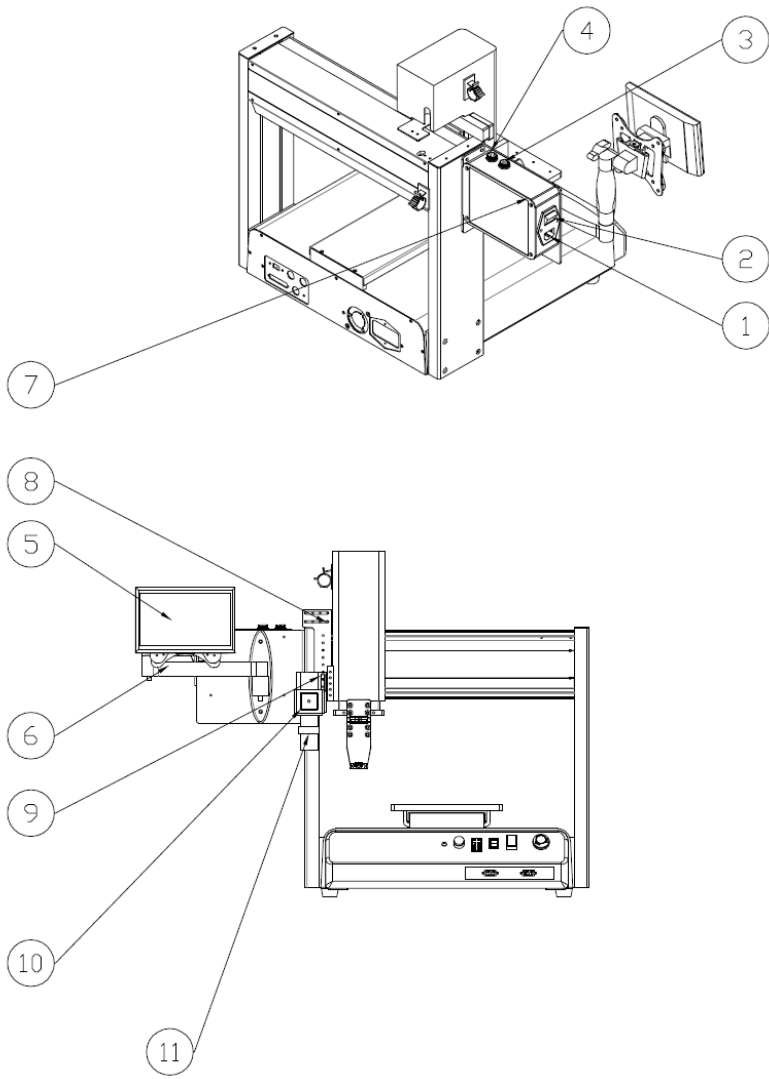

- 1. Power Inlet
- 2. Main Switch
- 3. 12VDC Port
- 4. 12VDC Port
- 5. Screen
- 6. Screen Bracket
- 7. Power Box
- 8. Bracket
- 9. CCD Bracket
- 10. CCD
- 11. Lens

2 Install Camera

2.1 Hardware Installation

Step 1. Remove X-axis's plate (1) of robot as below picture shown.

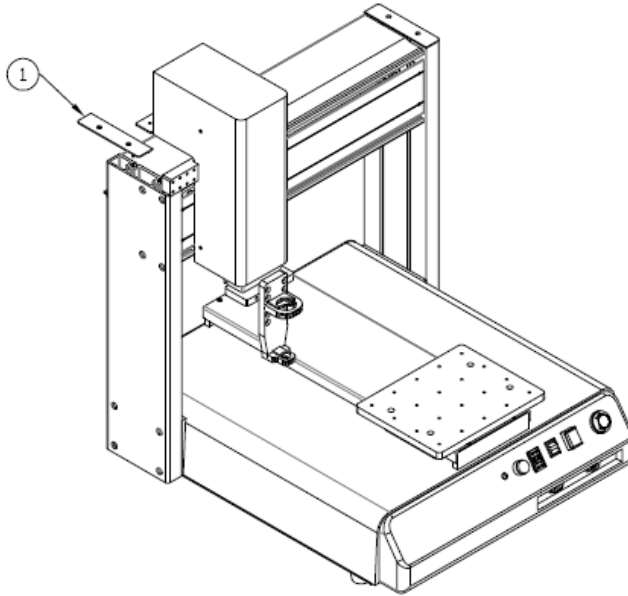

Step 2. Follow below picture, install bracket (2).

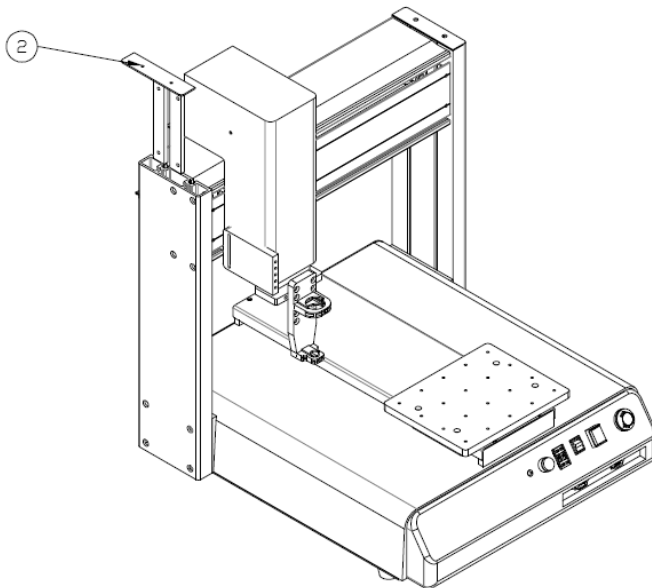

Step 3. Follow below picture, mount bracket (3) on D Robot

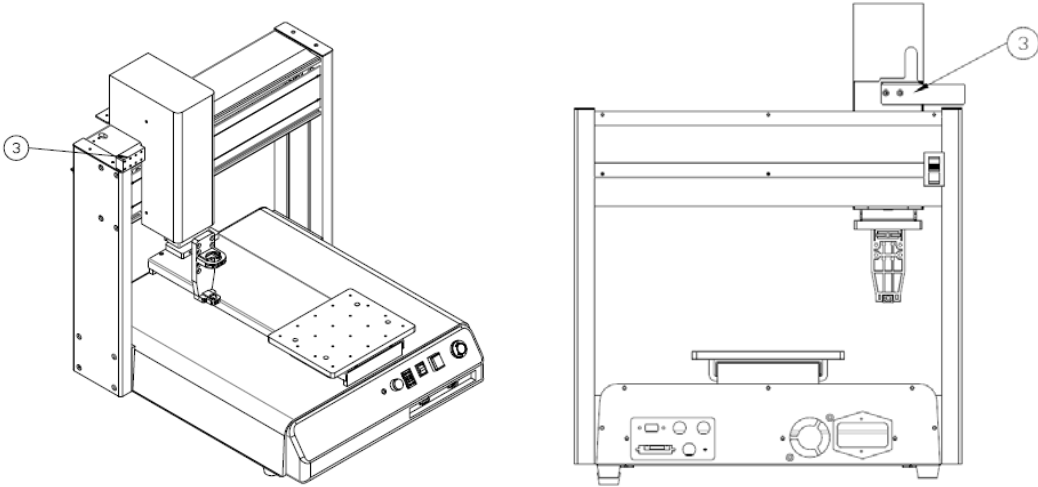

Step 4. Mount other bracket and CCD.

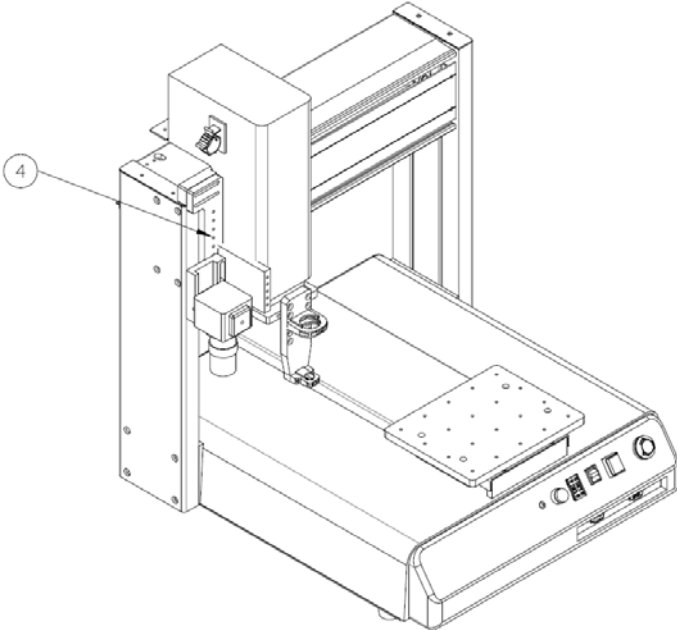

Step 5. Mount display and electrical cabinet.

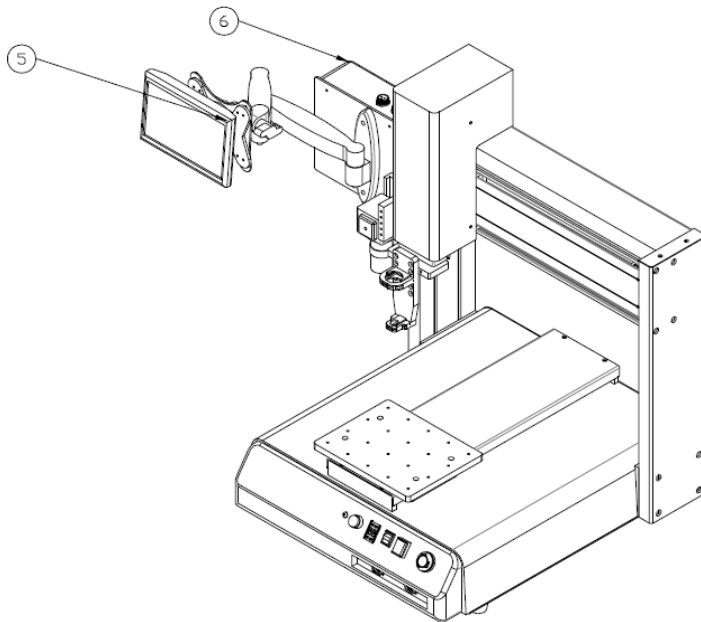

2.2 Wire Connection

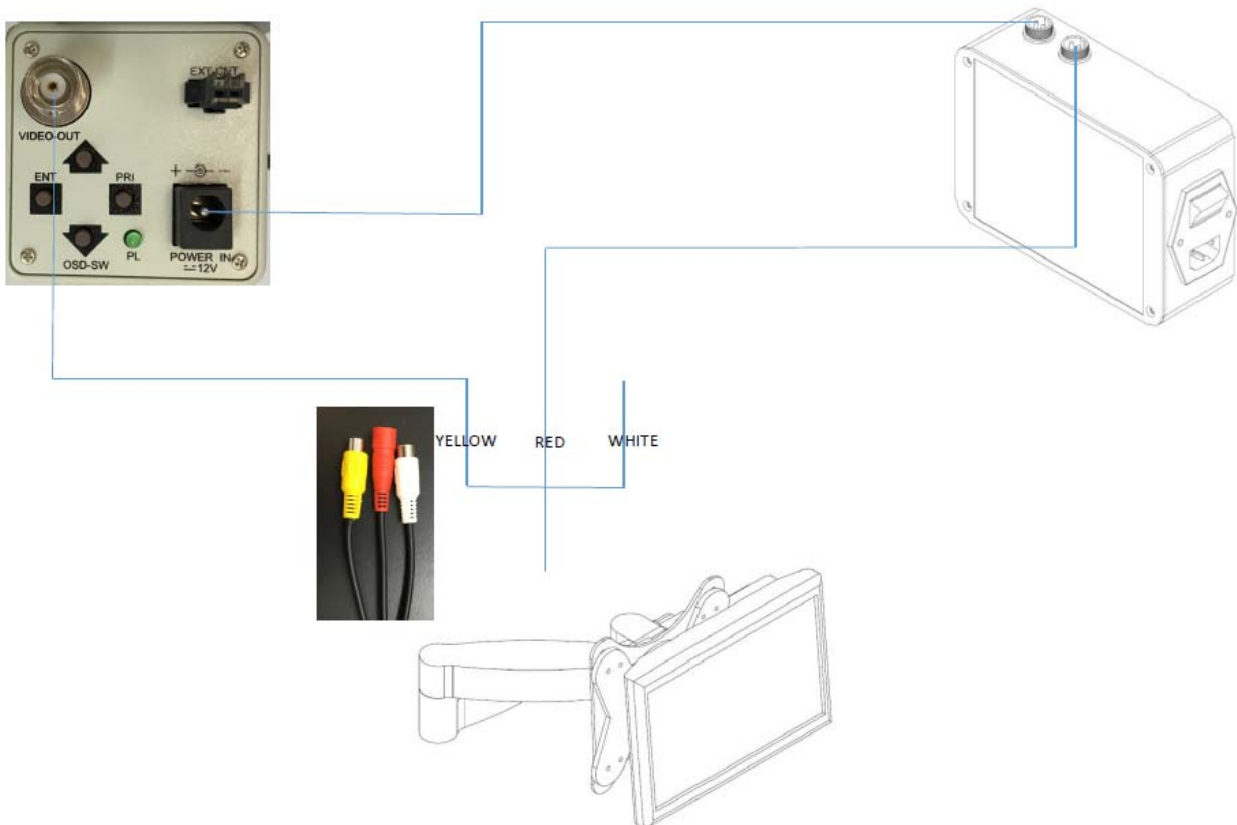

3 Get Started

A D-series robot with firmware version H6.1.1.293 is needed.

You are required to teach in offset between CCD and Tip at beginning.

Please go to menu F4→CCD Setup and Tip Setup.

3.1 CCD Setup

A CCD system with camera can be mounted on robot. You can program path by CCD and run by tip. You will need to target an existing point by both CCD and tip, so system can calculate the offset between lens and needle tip. System will recognize the offset and switch between those 2 modes.

<i>Instruction</i>	<i>Display Shows</i>
<p>F4 Menu →Page 4 →CCD Setup</p>	<pre>[CCD Setup] X:0.00 Y:0.00 Z:0.00 ----- 1:Save 2:Move Select: -----</pre>
<p>Move CCD to an existing point and target it by lens, make the point in the cross point of CCD screen.</p> <p>Press numbers to select if you want to Save or Move. Then press ENTER.</p> <p>Save: System will record current coordinate as reference coordinate, and use this coordinate when calculate offset to Tip mode.</p> <p>Move: Robot will move to previous coordinate that have done tip setup before and have been saved in system.</p>	<pre>[CCD Setup] X:0.00 Y:0.00 Z:0.00 ----- 1:Save 2:Move Select:</pre>

<i>Instruction</i>	<i>Display Shows</i>
Select. Then press ENTER.	<pre>[CCD Setup] X:0.00 Y:0.00 Z:0.00 ----- 1:Save 2:Move Select:1</pre>

3.2 Tip Setup

<i>Instruction</i>	<i>Display Shows</i>
F4 Menu →Page 4 →Tip Setup	<pre>[Tip Setup] X:0.00 Y:0.00 Z:0.00 ----- 1:Save 2:Move Select:</pre>
<p>Move tip to the same point which was used when CCD setup and target it.</p> <p>Press numbers to select if you want to Save or Move. Then press ENTER.</p> <p>Save: System will record current coordinate as reference coordinate, and use this coordinate when calculate offset to CCD mode.</p> <p>Move: Robot will move to previous coordinate that have done tip setup before and have been saved in system.</p>	<pre>[Tip Setup] X:0.00 Y:0.00 Z:0.00 ----- 1:Save 2:Move Select:</pre>
Select. Then press ENTER.	<pre>[Tip Setup] X:0.00 Y:0.00 Z:0.00 ----- 1:Save 2:Move Select:1</pre>

3.3 Edit Path Mode

System can run in both CCD and Tip mode. Mode can be switched in this command.

<i>Instruction</i>	<i>Display Shows</i>
F4 Menu →Page 4 →Edit Path Mode	[Edit Path Mode] Tip ----- 1:Tip 2:CCD Select: -----
Select running mode. Then press ENTER. I.e. To set running mode to CCD, press 2 then press ENTER. System will run path regarding CCD mode's coordinate	[Edit Path Mode] Tip ----- 1:Tip 2:CCD Select: -----
Select. Then press ENTER.	[Edit Path Mode] Tip ----- 1:Tip 2:CCD Select:2 -----

4 Accessories & Spare Parts

Loctite Item Number	Description
Robot	
2103369	RB40 500D 24V Benchtopy Robot
2104795	RB40 400D 24V Benchtopy Robot
2104799	RB40 300D 24V Benchtopy Robot
2104801	RB40 200D 24V Benchtopy Robot
2112253	RB15 200D Gantry Robot

5 Equipment Warranty

Henkel expressly warrants that all products referred to in this Instruction Manual for 1912406 EQ RB30 Robot Camera (hereafter called “Products”) shall be free from defects in materials and workmanship. Liability for Henkel shall be limited, as its option, to replacing those Products which are shown to be defective in either materials or workmanship or to credit the purchaser the amount of the purchase price thereof (plus freight and insurance charges paid therefor by the user). The purchaser’s sole and exclusive remedy for breach of warranty shall be such replacement or credit.

A claim of defect in materials or workmanship in any Products shall be allowed only when it is submitted in writing within one month after discovery of the defect or after the time the defect should reasonably have been discovered and in any event, within 12 months after the delivery of the Products to the purchaser. This warranty does not apply to perishable items, such as (fuses, filters, lights, etc.). No such claim shall be allowed in respect of products which have been neglected or improperly stored, transported, handled, installed, connected, operated, used or maintained. In the event of unauthorized modification of the Products including, where products, parts or attachments for use in connection with the Products are available from Henkel, the use of products, parts or attachments which are not manufactured by Henkel, no claim shall be allowed.

No Products shall be returned to Henkel for any reason without prior written approval from Henkel. Products shall be returned freight prepaid, in accordance with instructions from Henkel.

NO WARRANTY IS EXTENDED TO ANY EQUIPMENT WHICH HAS BEEN ALTERED, MISUSED, NEGLECTED, OR DAMAGED BY ACCIDENT.

EXCEPT FOR THE EXPRESS WARRANTY CONTAINED IN THIS SECTION, HENKEL MAKES NO WARRANTY OF ANY KIND WHATSOEVER, EXPRESS OR IMPLIED, WITH RESPECT TO THE PRODUCTS.

ALL WARRANTIES OF MERCHANTABILITY, FITNESS FOR A PARTICULAR PURPOSE, AND OTHER WARRANTIES OF WHATEVER KIND (INCLUDING AGAINST PATENT OR TRADEMARK INFRINGEMENT) ARE HEREBY DISCLAIMED BY HENKEL AND WAIVED BY THE PURCHASER.

THIS SECTION SETS FORTH EXCLUSIVELY ALL OF LIABILITY FOR HENKEL TO THE PURCHASER IN CONTRACT, IN TORT OR OTHERWISE IN THE EVENT OF DEFECTIVE PRODUCTS.

WITHOUT LIMITATION OF THE FOREGOING, TO THE FULLEST EXTENT POSSIBLE UNDER APPLICABLE LAWS, HENKEL EXPRESSLY DISCLAIMS ANY LIABILITY WHATSOEVER FOR ANY DAMAGES INCURRED DIRECTLY OR INDIRECTLY IN CONNECTION WITH THE SALE OR USE OF, OR OTHERWISE IN CONNECTION WITH, THE PRODUCTS, INCLUDING, WITHOUT LIMITATION, LOSS OF PROFITS AND SPECIAL, INDIRECT OR CONSEQUENTIAL DAMAGES, WHETHER CAUSED BY NEGLIGENCE FROM HENKEL OR OTHERWISE.

Henkel Corporation
One Henkel Way
Rocky Hill, CT 06067-3910

Henkel Canada Corporation
2515 Meadowpine Boulevard
Mississauga, Ontario L5N 6C3

Henkel Capital, S.A. de C.V.
Calzada de la Viga s/n Fracc. Los Laureles
Loc. Tulpetlac, C.P. 55090
Ecatepac de Morelos, Edo. de México

Henkel Corporation
Automotive / Metals HQ
32100 Stephenson Hwy.
Madison Heights, MI 48071

Henkel Ltda.
Rua Karl Huller, 136 – Jd.
Canhema 09941-410
Diadema/SP, Brazil

www.loctite.com

® and ™ designate trademarks of Henkel Corporation or its affiliates. ® = registered in the U.S. and elsewhere. © Henkel Corporation, 2009. All rights reserved. Data in this operation manual is subject to change without notice.

Manual P/N: 8905179, Date: 01/16/2017

