

PRODUCT DESCRIPTION

The volumetric rotor dispenser applies LOCTITE® adhesives, like anaerobics, acrylates and UV acrylates out of a reservoir with high repeatability. The limit of viscosity is 100,000 mPas.

The dispenser is a rotating displacement system. It consists of a rotor and a stator.

The different geometries of the rotor and stator cause the formation of cavities. Rotation of the rotor in the stator generates a flow that is proportional to rotary angle, and so delivery is speed-dependent.

The intrinsic self-sealing capability depends on the viscosity of the adhesive.

Do not operate the dispenser in an explosive atmosphere.

PRODUCT FEATURES

- Volumetric device, flow rate proportional to speed, electronically controlled.
- Dispenses anaerobics, acrylates and UV acrylates.
- Applications include drop or bead dispensing or potting.
- Integrated Luer lock-adaptor with O-ring (patented) ensures sealing in reverse flow!
- Because of the reversible direction of flow (suck-back) an exact stop of the product flow can be achieved.

Compact Rotor Dispenser 1.0 Includes

- Compact Rotor Pump Dispenser with stator and drive unit
- Mounting tool
- Feedline OD 6 mm, length 2 m
- Operating manual

Technical Data

- Dimensions (LxØ): 220 mm x Ø 35 mm
- Weight: 0.380 kg
- Volume per revolution: theoretically 0.05 ml
- Accuracy¹: ±1%
- Volume flow: 0.05 – 6.0 ml/min
- Input pressure: 0 – 6 bar
- Max. Dispensing pressure: 16 – 20 bar
- Intrinsic tightness²: approx. 2 bar
- Number of revolutions: 0 – 120 rpm
- Storage temperature: -10 °C to +60 °C (+14 °F to 140 °F), dry/dust free



- Operating temperature: +10 °C to +40 °C (+50 °F to +104°F)

Reference medium: Approx. 1.000 mPas at 20 °C.

- ¹ Volumetric dosing as absolute deviation relative to one dispenser rotation. Depending on the viscosity of the dispensing medium.
- ² Max. dispensing pressure and self-sealing decrease with decreasing viscosity and increase with increasing viscosity.

Spare Parts:

- Repair kit, consists of 2 O-rings each 2.9x0.6 (FKM), 13x1.25 (FFKM), 13x1.5 (FKM), 16x1.25 (FKM), 17x1.25 (FKM); P/N 1335043
- Repair kit, O-ring 2.9x0.6 (5 pcs); P/N 1679908
- Stator with housing; P/N 1335041
- Pump unit without motor; P/N 1335042
- Sealing set with housing; P/N 1335000

Dimensions:

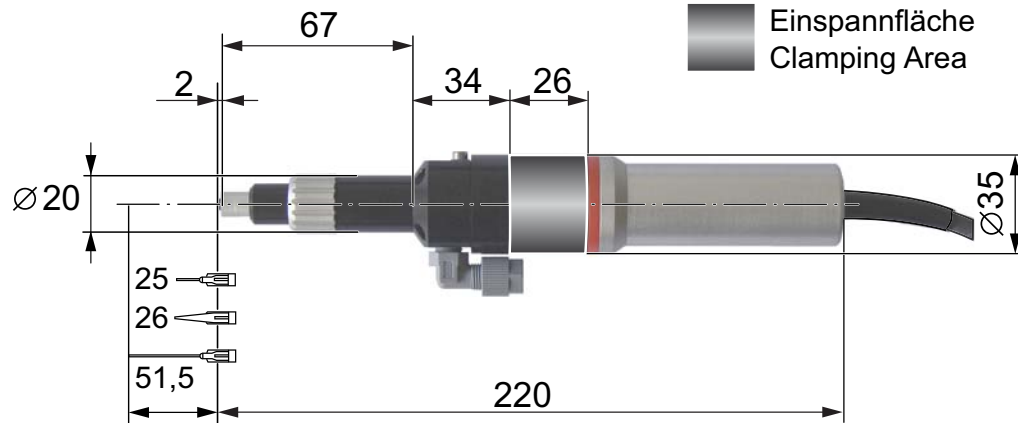

Overview of salable Systems:

System for dispensing quantity: 0,5 to 6,0 ^{ml} /min Order No. 1197319	System for dispensing quantity: 0.12 – 1.48 ml/min Order No. 1654036
Content: – Compact Rotor Pump Controller, Type 97150 incl. external power supply – Compact Rotor Dispenser 4.0, Type 97611	Content: – Compact Rotor Pump Controller, Type 97150 incl. external power supply – Compact Rotor Dispenser 1.0, Type 97621

Note

The data contained herein are furnished for information only and are believed to be reliable. We cannot assume responsibility for the results obtained by others over whose methods we have no control. It is the user's responsibility to determine suitability for the user's purpose of any production methods mentioned herein and to adopt such precautions as may be advisable for the protection of property and of persons against any hazards that may be involved in the handling and use thereof. In light of the foregoing, Henkel Corporation specifically disclaims all warranties expressed or implied, including warranties of merchantability or fitness for a particular purpose, arising from sale or use of Henkel Corporation's products. Henkel Corporation specifically disclaims any liability for consequential or incidental damages of any kind, including lost profits. The discussion herein of various processes or compositions is not to be interpreted as representation that they are free from domination of patents owned by others or as a license under any Henkel Corporation patents that may cover such processes or compositions. We recommend that each prospective user test his proposed application before repetitive use, using this data as a guide. This product may be covered by one or more United States or foreign patents or patent applications.

Trademark usage

Except as otherwise noted, all trademarks in this document are trademarks of Henkel Corporation in the U.S. and elsewhere. ® denotes a trademark registered in the U.S. Patent and Trademark Office.

Edition 09/2014, Part# 8955819, Rev 2