

Loctite® Robot Safety Light Curtain Interfacing

The safety light curtain was designed and built to for use with Henkel robots. When the Robot guarding package is delivered, there are only 2 cables (aside from the power cord), which will require wiring connections necessary to activate the system.

1. Ensure that the Robot is OFF.
2. Ensure that the guarding control cabinet is unplugged.
3. The E-Stop should be wired to the Control Panel; if it is not, connect the small enclosure (with the E-stop button) to the cable labeled R (terminals 1 and 3 in the enclosure).
4. Make wiring additions by splicing into the cable assembly coming out of the control panel labeled S. See the electrical schematic (attached) for reference.

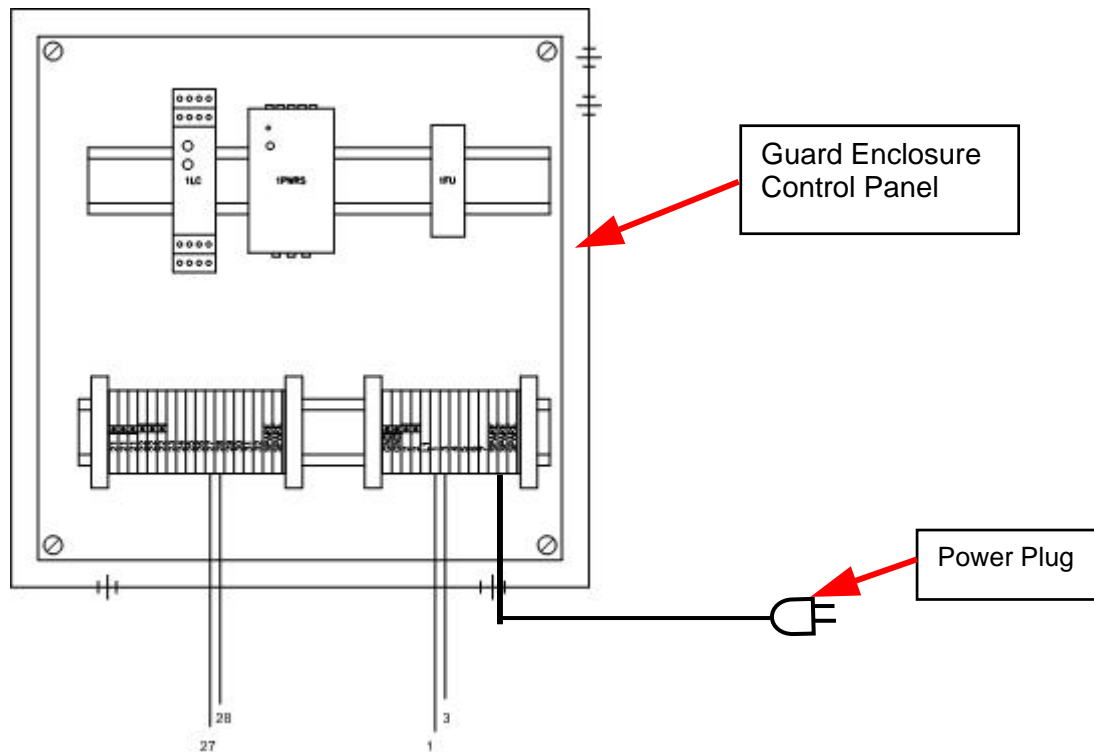

- a. Connect the S-Connector cable (from the guard control panel label S) to the Robot S-Plug (rear of Robot). The S-Connector plug typically ships with the two wires shorted (twisted together). Remove the twisted pair and connect to the 2- conductor cable—make sure you insulate the connection properly!

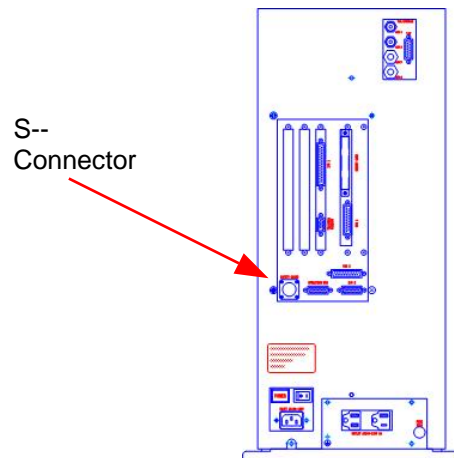

5. Connect the Teach Pendant to the Robot.
6. Plug the Guarding enclosure power cable to the appropriate AC power outlet.
7. Turn the Robot power switch (rear of Robot) to ON.
8. Pull the RESET button on the Guarding enclosure operator panel, and on the small E-Stop enclosure.
9. Depending on how the robot was left (on previous shut-down) it will be necessary to change modes to access the robot and place in TEACH mode.
10. Press the MENU key, select Run Mode Parameters, select I/O Settings, and then select I/O-S Function Settings, Select Interlock.
11. Next, go to the Administration Mode and select Administration settings, select Start Channel and set to IO-SYS.
12. The system is now ready to operate. Place the robot in a dispense program, set the robot to External Run Mode. It may be necessary to press the External Start pushbutton twice if the robot requires re-initialization.
13. Parts can be loaded or unloaded without affecting the Robot so long as the Robot is idle (cycle completed).
14. The Robot will loose power to its motors if the light curtain is interrupted during Robot cycling.
15. If the Light Curtain is interrupted in the middle of a cycle, it will be necessary to initialize the Robot by pressing the Start pushbutton.
16. If the E-Stop button is depressed on the Light Guarding Enclosure, power to the Robot and any equipment plugged to the rear of the unit will be removed.

If using the 98636 Interface cable (instead of the 98549 J-Box):

1. Connect the S-Connector as in the previous procedure—step 4b above.

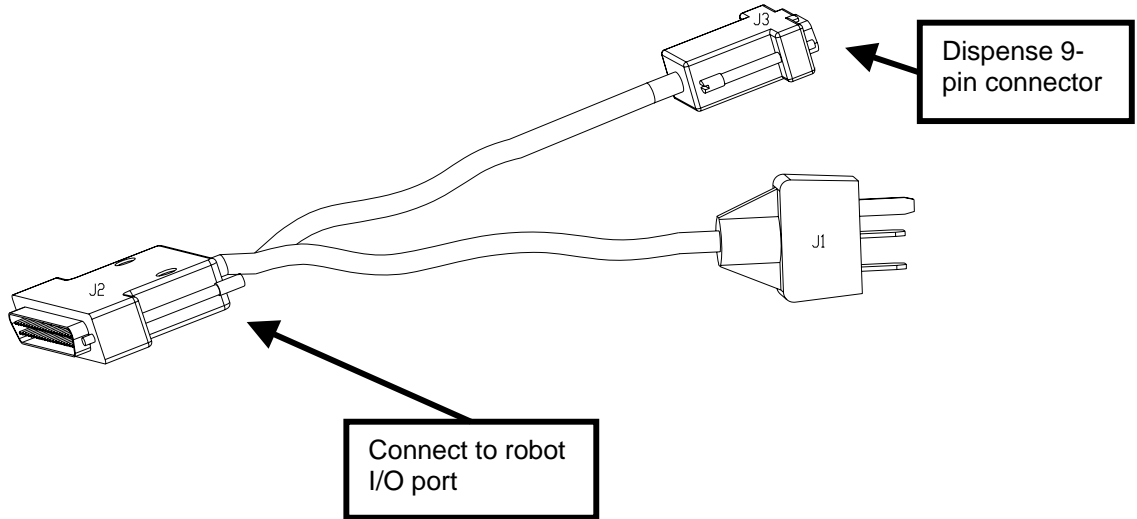

2. This cable has the 9-pin sub D connector to actuate most Loctite controllers. This cable also has the 3-pin Jones connector used to actuate Loctite 98021 Analog Syringe Controller and the 98521 Spray Controller.

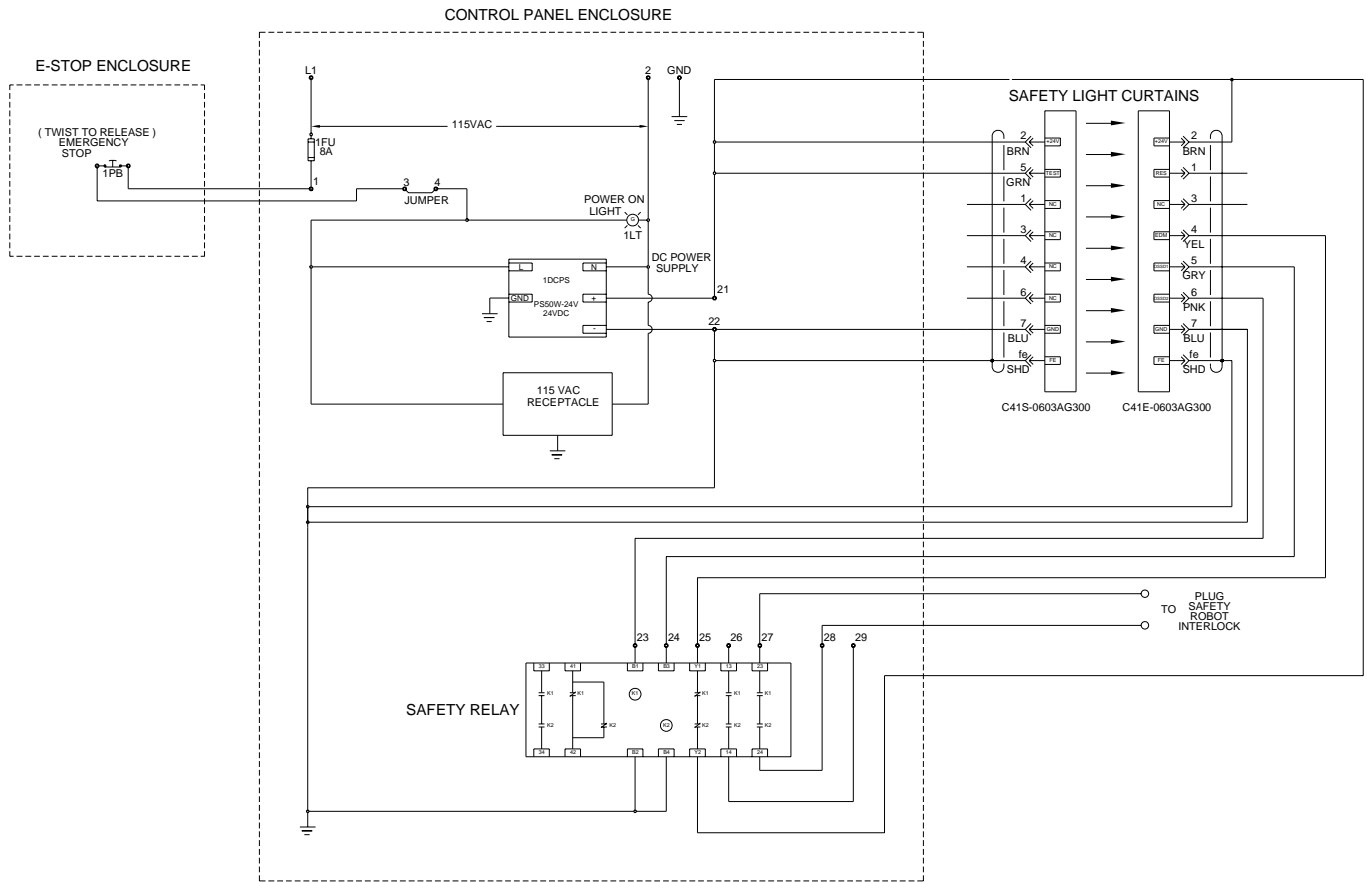

Henkel Corporation
 1001 Trout Brook Crossing
 Rocky Hill, CT 06067-3910

Henkel Canada Corporation
 2225 Meadowpine Boulevard
 Mississauga, Ontario L5N 7P2

Henkel Capital, S.A. de C.V.
 Calzada de la Viga s/n Fracc. Los Laureles
 Loc. Tulpetlac, C.P. 55090
 Ecatepec de Morelos, Edo. de México

**Henkel Automotive
 Technology Center**
 2455 Featherstone Road
 Auburn Hills, Michigan 48326

Henkel Ltda.
 Rua Karl Huller, 136 – Jd.
 Canhema 09941-410
 Diadema/SP, Brazil

www.loctite.com

Loctite is a trademark of Henkel Corporation, U.S.A. © Copyright 2004. Henkel Corporation
 All rights reserved. Data in this operation manual is subject to change without notice.
 Manual P/N: 989859 Rev A, Date: 04/2006

